

NRS Gate Valve, Resilient Wedge Gate Valve FL × MJ Ends - 300PSI, Size 4"-12"

FIG. F1811-300

Specifications

- Manufactured to ANSI / AWWA C509 Standard
- Flanged Ends comply with ANSI B16.1, Class 125 (Other flange types available upon request).
- Mechanical Joint End to ANSI / AWWA C153 / A21.53 Standard.
- Resilient Seated / EPDM Encapsulated DI Wedge.
- 2" Square Operating Nut or Hand Wheel (Optional).
- High Strength Ductile-Iron Construction.
- Stainless Steel Stem.
- UL / ULC Listed / FM Approved.

Working Pressure

- 300PSI.
- 200PSI and 250PSI available on request.

Working Temperature

- -10 to 82°C

Corrosion Protection

- Fusion Bonded Epoxy Coated Internally and Externally to AWWA C550 Standard.
- 250 microns minimum coating thickness.

Material Specifications

No.	Part Name	Material
1	Body	Ductile Iron, A536 65-45-12
2	Wedge	Ductile Iron A536 65-45-12, EPDM Encapsulated
3	Wedge Nut	Bronze, C95200
4	Stem	Stainless Steel, SS304
5&6&7	Bolt & Washer & Nut	Stainless Steel, A2-70 & A2-70 & A4-70
8	O-Ring	NBR
9	Bonnet	Ductile Iron, A536 65-45-12
10	O-Ring	NBR
11	Thrust Washer	Bronze, C95200
12	O-Ring	NBR
13	Gland	Ductile Iron, A536 65-45-12
14	Operating Nut	Ductile Iron, A536 65-45-12
15&16	Bolt & Washer	Stainless Steel, A2-70 & A2-70
17&18&19	Bolt & Washer & Nut	Stainless Steel, A2-70 & A2-70 & A4-70
20	Handwheel	Ductile Iron, A536 65-45-12

Dimensions (inch)

Size	4"	6"	8"	10"	12"
L	9.5	11.0	12.0	14.0	14.5
H	16.0	19.0	23.0	26.0	30.7
D	10.0	12.0	14.0	17.5	17.5
A	7.0	8.5	9.5	11.5	12.0

Schematic

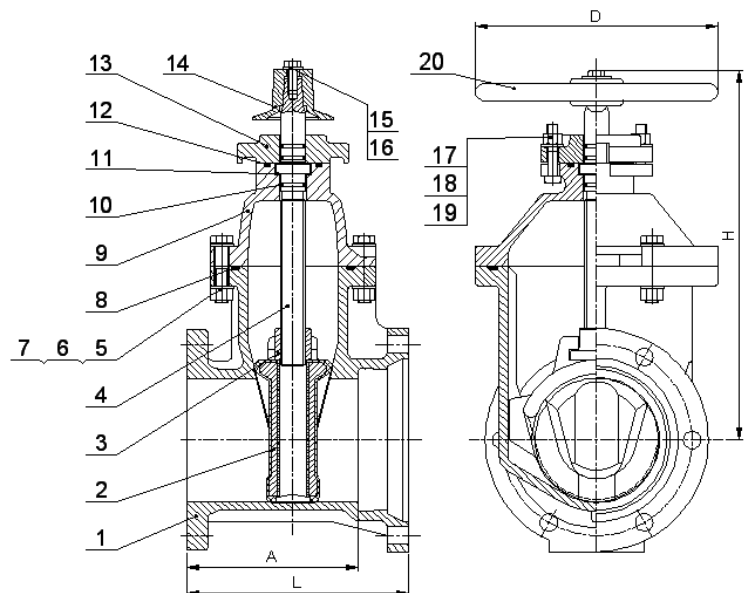
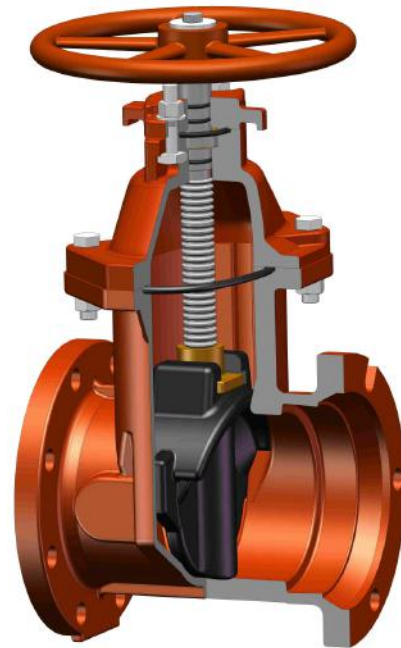

The designs, materials and specifications shown are subject to change without notice due to the continuous development of our products.